

Aquaculture Biology Laboratory

Faculty of Fisheries Nagasaki University



Professor: Dr. Atsushi Hagiwara (hagiwara@nagasaki-u.ac.jp)
Dr. Yoshitaka Sakakura (sakakura@nagasaki-u.ac.jp)
Address: Bunkyo 1-14, Nagasaki 852-8521, Japan
Tel: +81-95-819-2830 or 2823, Fax: +81-95-819-2799

Research projects and plan-do-action of our laboratory

Seedling production (Live feeds & larval rearing)

Aquaculture



The 'live feed'
Rotifer
(0.2 mm BL)



Larva of seven-band grouper
(day 4, 2 mm BL)



Seven-band grouper
(~90 cm BL)

Research Projects

Produce good quality of new target species
→ from empirical to scientific approach

I. Development of live feed planktons

1) Breeding and stock culture of live feed planktons

Culture collection of rotifers1

Gene analysis of rotifers 2

Resting eggs of rotifers3

Health diagnosis of planktons4

Biologically active substances.....5,6

2) New species for live feed7

II. Larval rearing

3) Diagnosis of fish health8

4) Optimal feeding regime9

5) Optimal rearing tank10

III. Publications and Patents11,12

Feedback

Novel rearing system

Nagasaki Prefectural Fisheries Experimental Station

Fish farmer, etc...

1. Breeding project of rotifers

Goal: Development of new rotifer strains efficient for larval rearing

- Outcomes: i) Cross breeding between rotifers of different strains
 ii) Biological characteristics in cross-breeding strains

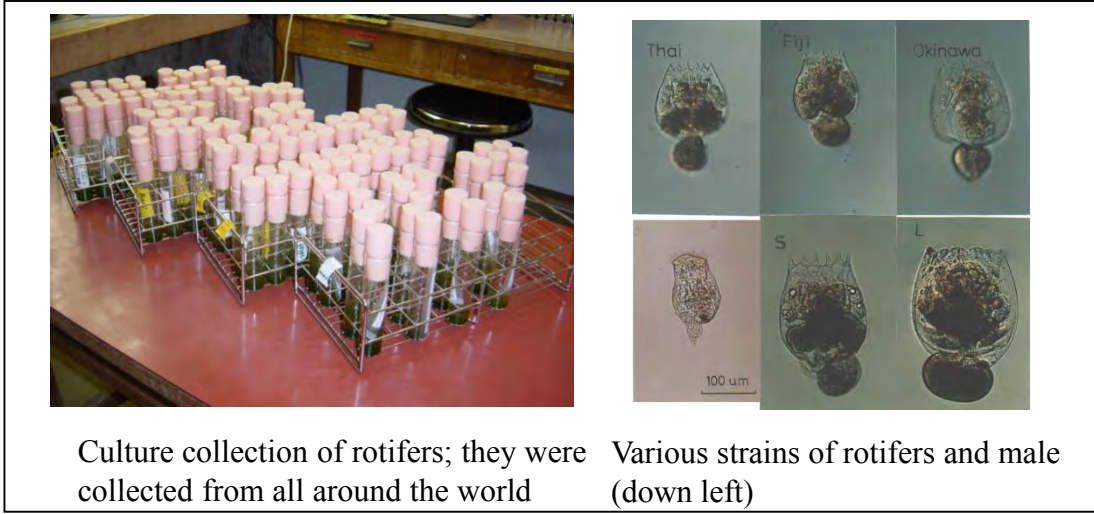

Strain selection

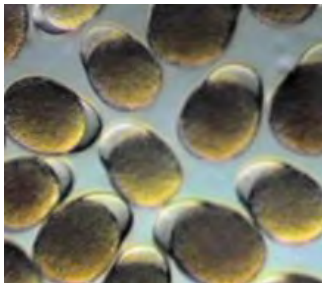
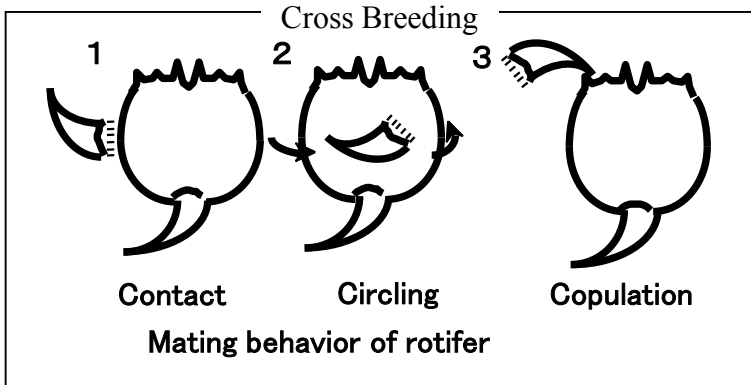

Fertilized eggs (resting eggs)

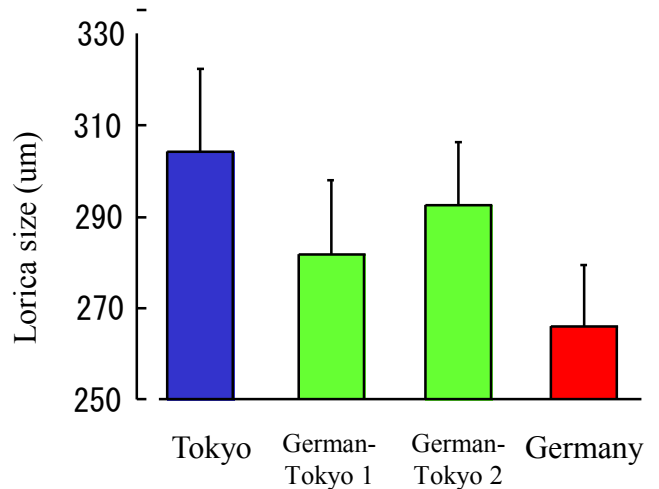
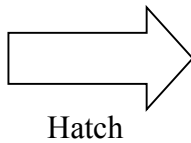

2. Construction of expressed sequence tag (EST) and development of transformation method on rotifer

Goal:

- 1) To construct rotifer EST in order to create cDNA database.
- 2) To isolate and identify specific genes on rotifer life cycle (male, amictic female and mictic female) by differential display PCR.
- 3) To create new rotifer strain by genetic manipulation based on the above genetic data.

Outcomes:

- 1) We established an axenic culture method of rotifers by initially using antibiotics. This culture is useful to prevent other organismal DNA in constructing EST (pat. 2003-382155).
- 2) We isolated mRNA from axenic rotifer culture and constructed cDNA library.
- 3) We established a transformation technique for rotifer resting eggs using micro manipulator (under patent application and preparation).
- 4) We sequenced full mtDNA of rotifer!



Axenic rotifer culture

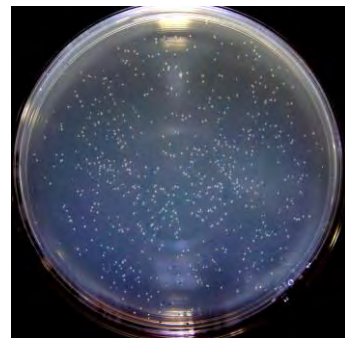
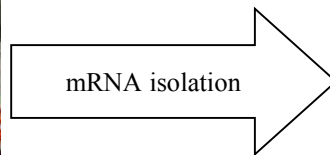

cDNA library of the rotifer

(plasmid vector with cDNA in *E. coli*)

Suga, K., Welch, D.M., Tanaka, Y., Sakakura, Y. & Hagiwara, A. (2007) Analysis of expressed sequence tags of the cyclically parthenogenetic rotifer *Brachionus plicatilis*. PLoS ONE 2(8), 1-7.

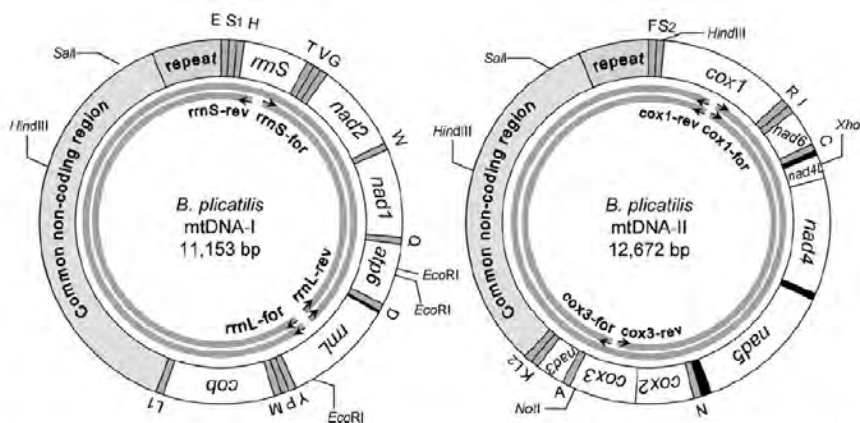

FIG. 1.—Maps of the 2 mitochondrial chromosomes in the rotifer *Brachionus plicatilis*. All genes are transcribed from the same DNA strand, clockwise as these maps are oriented. Protein-coding genes and rRNA genes are indicated in white and are designated by standard nomenclature; tRNAs are indicated in gray and are identified by 1-letter code for the corresponding amino acid except the 2 serine and 2 leucine tRNAs: S1, S2, L1, and L2 are *trnS(agn)*, *trnS(uac)*, *trnL(cua)*, and *trnL(uar)*, respectively. The common NCR is indicated in light gray, with the repeat region indicated by lateral stripes; other NCRs are indicated in black. Sites for restriction enzymes used for Southern blot analysis in figure 2, *EcoRI*, *HindIII*, *NotI*, *SalI*, and *XhoI* are shown. Arrows and gray curves within each circle indicate primers and amplicons, respectively, used for sequencing. Scaling is approximate.

Suga, K., Welch, D.M., Tanaka, Y., Sakakura, Y. & Hagiwara, A. (2008) Two circular chromosomes of unequal copy number make up the mitochondrial genome of the rotifer *Brachionus plicatilis*. Molecular Biology and Evolution 25(6), 1129-1137.

3. Rotifer resting eggs: preserved product of live feed for marine fish larvae

Goal: Development of techniques to mass-produce rotifer resting eggs

Outcomes

- ① Rotifer resting egg production by regulating life cycle
(Pat-465050, Pat 2003-323257)
- ② Artificial sea water for maximizing rotifer resting egg production
(Pat 2003-072203)
- ③ Resting egg production at the order of 10^{10} and preservation by canning

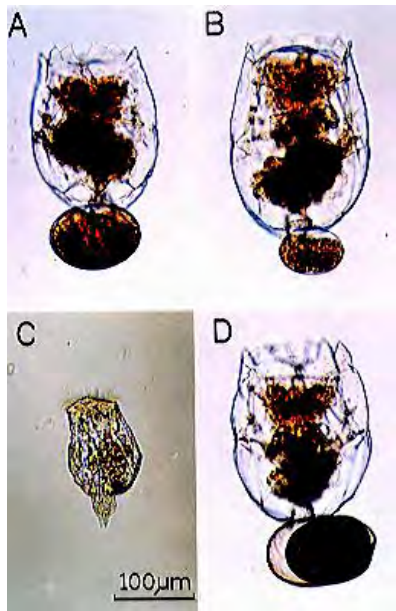

Three female types (A,B,D) and male (C) of marine rotifers

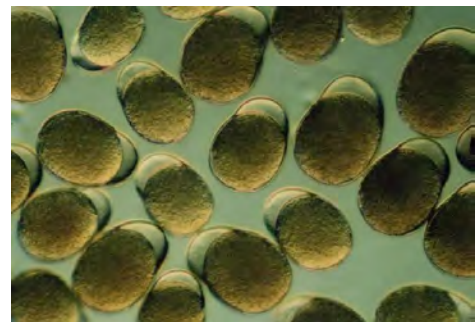

Rotifer resting eggs



Rotifer resting eggs mass-produced in a 50 m³ tank



Resting egg can containing 10 million resting eggs

4. Diagnosis of culture status of zooplankton used as live food for rearing fish larvae

Goal : To develop techniques to assess the physiological status of mass cultured marine rotifers used for feeding fish larvae.

Outcomes:

Environmental changes affect physiological status of rotifers, resulting in the change of life span and fecundity. We confirmed that such changes in demographic parameters correlate with the change in ingestion rate and swimming speed of rotifers.

We further tested the effects of environmental changes on rotifer enzyme activity, and found that it correlates well with rotifer demographic parameters. The use of fluorescent substrate simplifies the process for enzyme activity measurement.

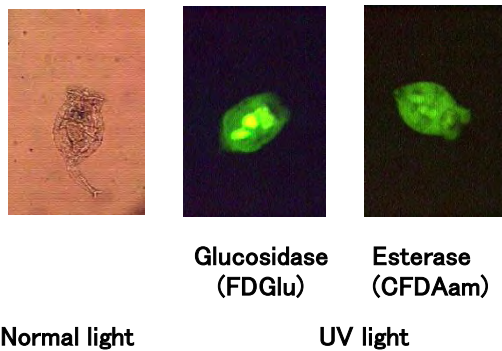

Health check of rotifers

“More fluorescence from viable rotifers”

“Less fluorescence from weak rotifers...”

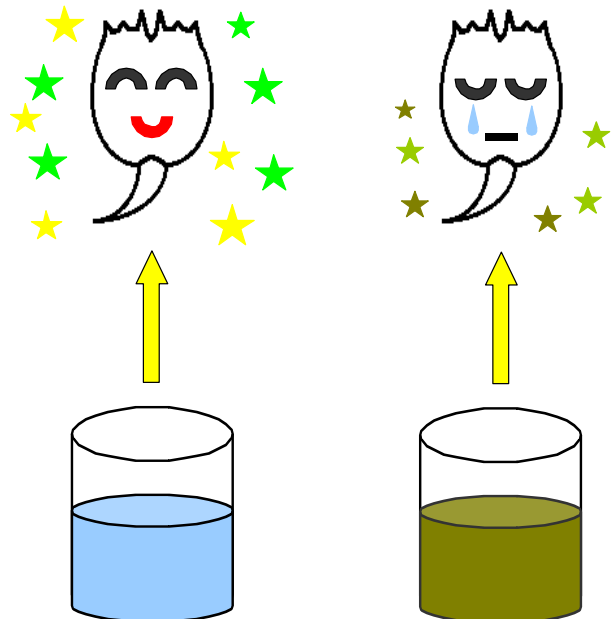

- ✓ Araujo, A. B. de & A. Hagiwara (2005) Screening methods for improving rotifer culture quality. *Hydrobiologia* 546: 553-558.
- ✓ De Araujo, A.B., Snell, T.W., Hagiwara, A. (2001) *Hydrobiologia*
- ✓ De Araujo, A.B., Snell, T.W., Hagiwara, A. (2000) *Aquaculture Research*

5. Effect of hormone treatments on life history of marine rotifers

Goal: There are few information about endocrine system of marine rotifers. We examined the effects of the addition of vertebrate and invertebrate hormones on rotifer demographic parameters.

Outcomes

- ① Among 16 hormones tested (including neurotransmitters), the addition of γ -amino-butyric acid (GABA) and porcine growth hormone (GH) promote rotifer population growth. Serotonine (5-HT) and juvenile hormone treatments induced resting egg formation.
- ② Effective GABA effects were seen when rotifer cultures are not viable under stressed condition.
- ③ GABA and 5-HT exist in rotifers (HPLC analysis), probably indicating that these function as neurotransmitters in rotifers. GH like substance was found in rotifers, which immuno-react with the antibody of porcine growth hormone.

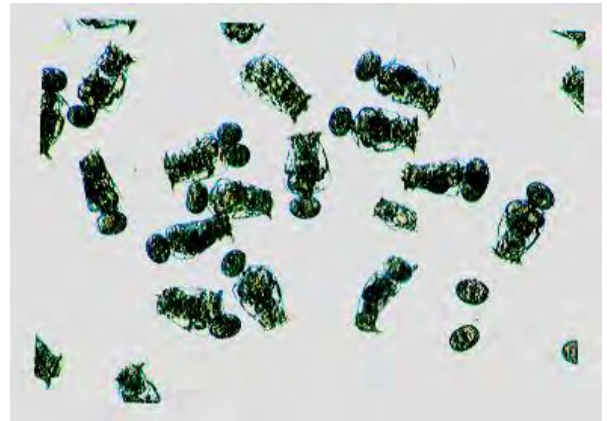
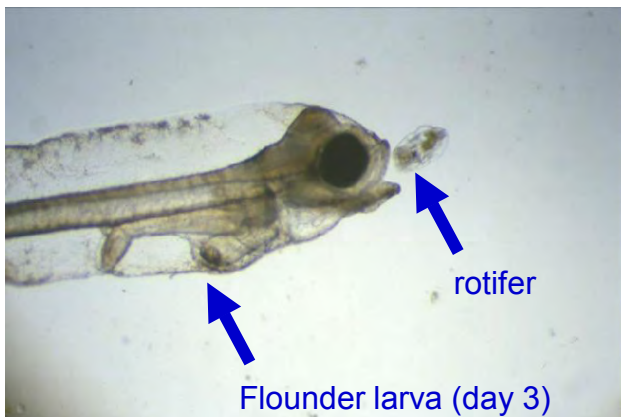

Rotifers in mass cultures

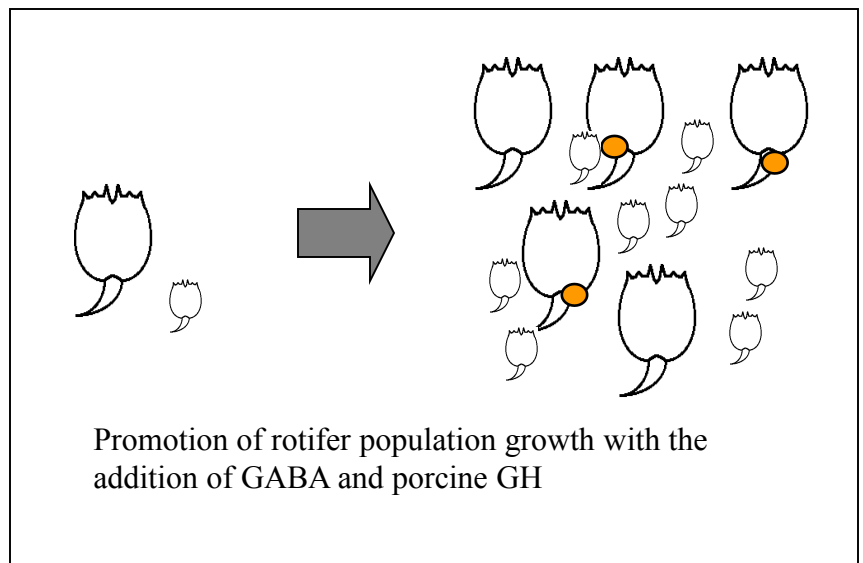
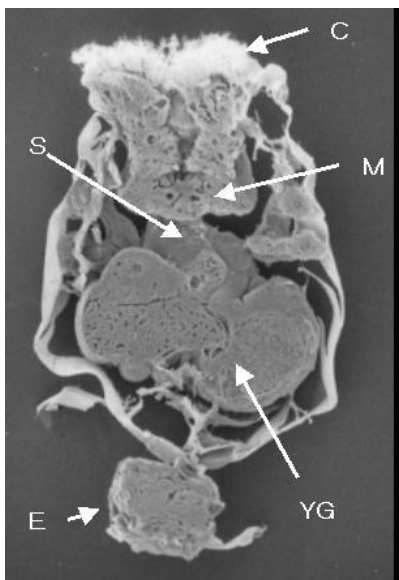

Histological section of marine rotifers; rotifers are metazoans composed of about 800 cells.

- ✓ Assavaaree, M., Hagiwara, A. (2011) Fisheries Science
- ✓ Gallardo, W.G., Hagiwara, A., Hara, K., Soyano, K. (2006) Fisheries Science
- ✓ Araujo, A., Hagiwara, A. (2005) Hydrobiologia
- ✓ Gallardo, W.G., Hagiwara, A., Snell, T.W. (2001) Aquaculture Research

6. Effects of known and suspected endocrine disrupting chemicals (EDCs) on marine zooplankton



Cladoceran

Diaphanosoma celebensis



Copepod

Tigriopus japonicus

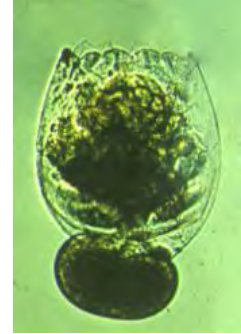

Rotifer

Brachionus plicatilis

Goal:

To investigate how EDCs affect zooplankton.

Outcomes:

- 1) Some EDCs (e.g. 17β -estradiol) increases fecundity of cladoceran.
- 2) Estrogen and estrogenic compounds affect development of copepods.
- 3) Some pesticides affect the hatchability of resting eggs of rotifers.

- ✓ Dahms, H.-U., Hagiwara, A., Lee, J.-S. (2011) Aquatic Toxicology
- ✓ Marcial, H.S., Hagiwara, A (2007) Hydrobiologia
- ✓ Marcial, H.S., Hagiwara, A (2007) Fisheries Science
- ✓ Marcial, H.S., Hagiwara, A., Snell, T.W. (2005) Hydrobiologia
- ✓ Marcial, H.S., Hagiwara, A., Snell, T.W. (2003) Environmental Toxicology and Chemistry

7. Development of culture methods for marine copepods

Goal: Development of novel live feed for fish larva

- Outcomes: ① Establishment of culture method for marine copepods
② Long-term culture of copepods from one batch
③ Selection of micro algae for marine copepods

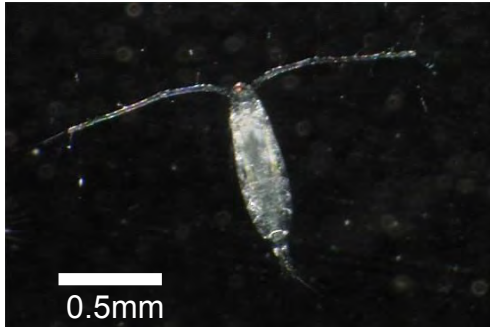

Marine copepod, *Acartia tsuensis* (adult)

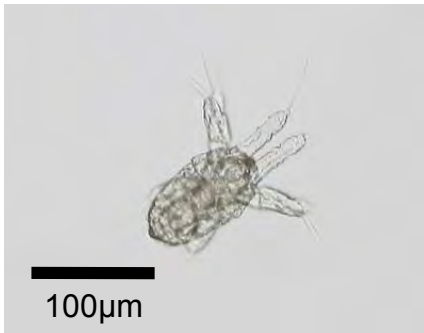

Nauplius of *Acartia tsuensis*



Small scale (5 L) culture system



20 L-scale copepod culture system with continuous feeding system



Mass culture system for copepods (400 L)

8. Development of health diagnosis for marine fish larvae

Goal: To establish real-time monitoring system for status of marine fish larvae in the process of seedling production.

Outcomes:

- ① We found that enzyme activity and behavior of newly hatched larvae have significant positive correlation with health conditions and quality of fish.
- ② We established individual-base enzyme assay system using clonal lineages of an excellent model fish *Rivulus marmoratus*, that is the only known self-fertilizing vertebrate.
- ③ Real-time diagnosis for health conditions and quality of neonates in the viviparous scorpionfish *Sebastiscus marmoratus* using enzyme activity and behavior (Pat. 3493432).
- ④ We are developing the behavior-analysis computer program, which enables us to observe fish behavior individually, in the collaboration with Industrial Technology Center of Nagasaki Prefecture.

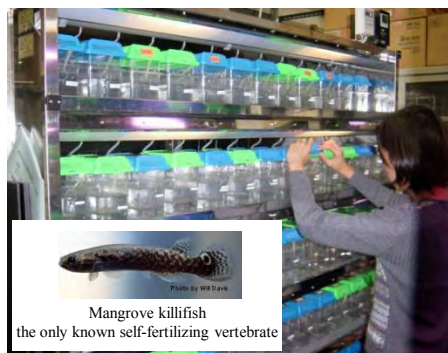

Rearing experiments in the lab.

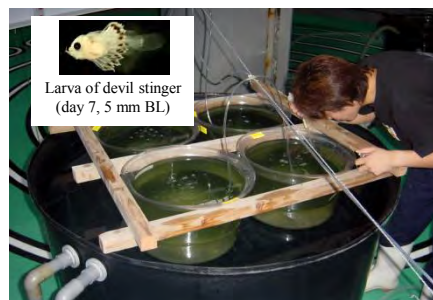

Rearing experiments in Nagasaki Prefectural Fisheries Experimental Station

Diagnosis of larval quality using enzyme assay and behavioral analysis

Individual based enzyme assay

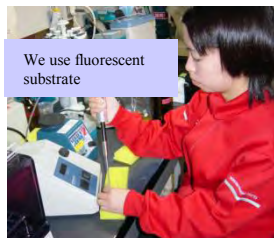

Behavioral analysis

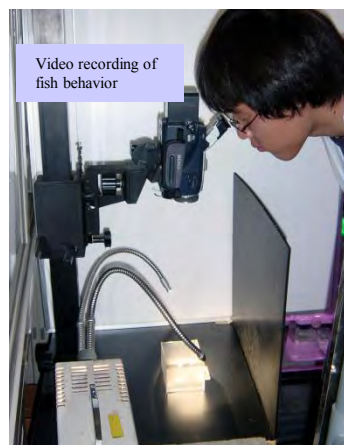

- ✓ Matsuo, Y., Kasahara, Y., Hagiwara, A., Sakakura, Y. & Arakawa, T. (2006) Evaluation of larval quality of viviparous scorpionfish *Sebastiscus marmoratus*. *Fisheries Science* 72(5), 948-954.
- ✓ Ruttanapornvareesakul, Y., Sakakura, Y. & Hagiwara, A. (2010) Screening of enzyme activity for assessing the condition of larvae in the seven-band grouper *Epinephelus septemfasciatus* and devil stinger *Inimicus japonicus*. *Fisheries Science* 76(2), 295-304.

9. Development of optimal feeding regime for marine fish larvae

Goal:

To establish the optimal feeding regime during the live feed period of marine fish larvae.

Outcomes:

① We revealed the size-selectivity on live feeds (rotifer and *Artemia*) for the larvae of the seven-band grouper (*Epinephelus septemfasciatus*) and devil stinger (*Inimicus japonicus*).

② We tested a new feeding regime for seven-band grouper based on its feeding selectivity, and found that survival, growth and quality (DHA composition) of larvae are better than the former feeding regime.

Rearing experiment

Analysis of growth, morphology and feeding incidence

Analysis of feeding selectivity

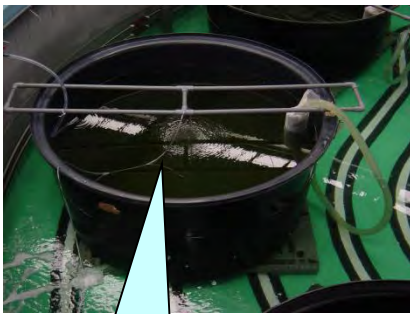

Larva of the seven-band grouper
(day 20, 4 mm BL)

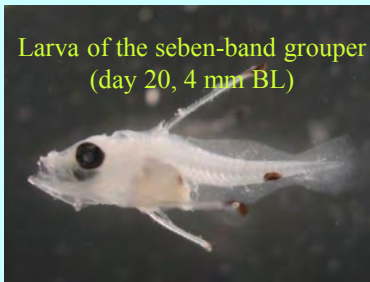

Removal of intestine



Intestine

Analysis of numbers and
size of ingested rotifers

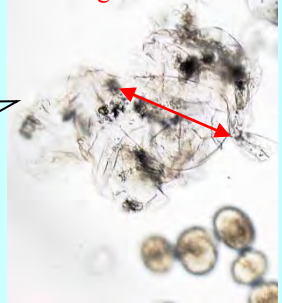

Analysis of feeding selectivity for marine fish larvae

- ✓ Tanaka, Y., Sakakura, Y., Chuda, H., Hagiwara, A. & Yasumoto, S. (2005) Food selectivity of seven-band grouper *Epinephelus septemfasciatus* larvae fed different sizes of rotifers. *Nippon Suisan Gakkaishi* 71, 911-916.
- ✓ Akazawa, A., Sakakura, Y. & Hagiwara, A. (2008) Feeding selectivity of marine fish larvae, *Verasper variegatus*, *Seriola quinqueradiata* and *Platycephalus* sp. on different sizes and shape of three rotifer strains. *Nippon Suisan Gakkaishi* 74(3), 380-388.
- ✓ Pandey, B.D., Hagiwara, A. & Sakakura, Y. (2008) Feeding behaviour, feed selectivity and growth studies of mangrove killifish, *Kryptolebias marmoratus* larvae using various live and formulated feeds. *Environmental Biology of Fishes* 82(4), 365-375.

10. Development of optimal rearing tank for marine fish larvae

Goal:

To develop optimal rearing tank by synthesizing the 2 approaches from hydrodynamics of the rearing tank and behavioral analysis of fish larvae and planktons in the rearing tank. This project is the collaboration with Prof. Shigeaki Shiotani, Kobe University, Japan.

Outcomes:

By the measurements of the flow field in the rearing tank and distributions of seven-band grouper larvae and rotifers in the rearing tank, we established an optimal rearing tank (Pat.2003-412841). This rearing system enabled 3 times higher survival of grouper larvae than usual rearing system.

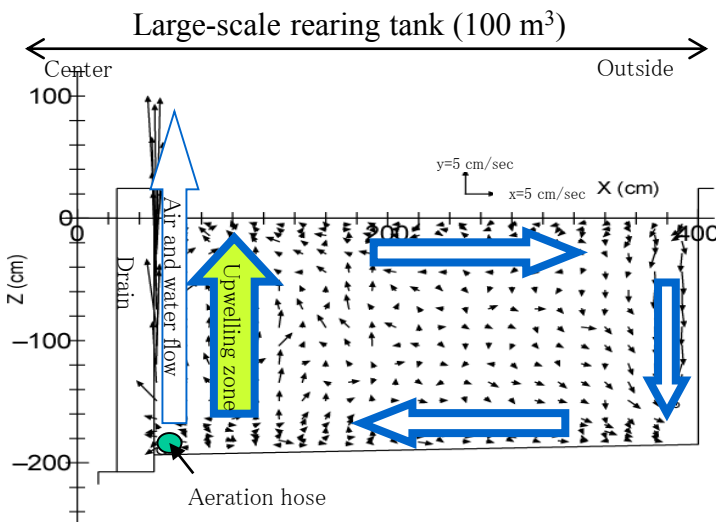
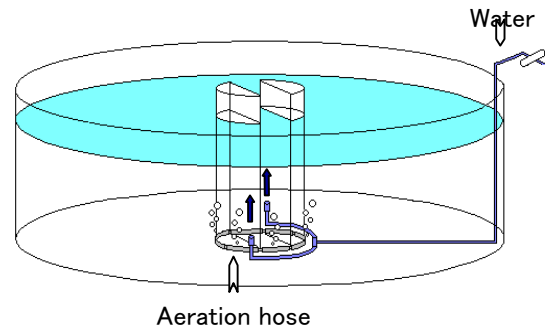
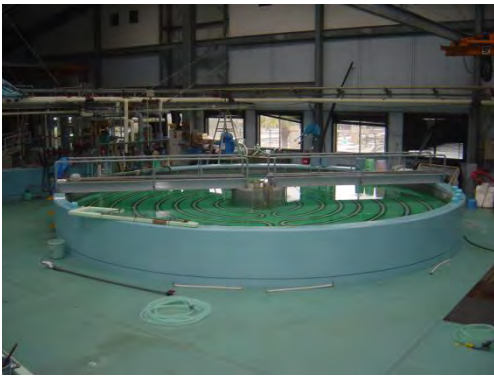

Schematic drawing of new rearing tank

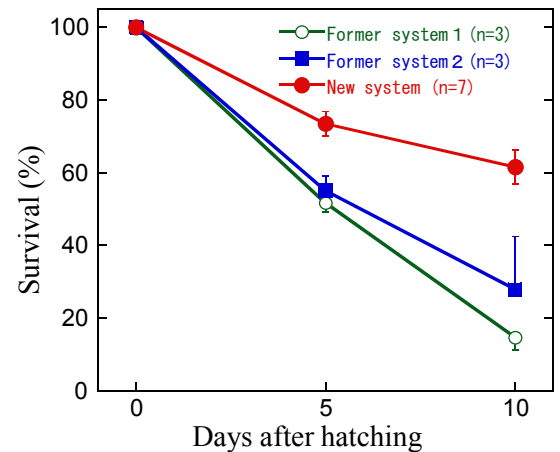

Two dimensional water flow in new rearing tank

Note the upwelling zone, which avoids direct contact of larvae with air bubbles and strong water flow

This system ensures the high survival of grouper larvae

- ✓ Sakakura, Y., Shiotani, S., Chuda, H. & Hagiwara, A. (2007) Flow field control for larviculture of the seven-band grouper *Epinephelus septemfasciatus*. *Aquaculture* 268, 209-215.
- ✓ Ruttanapornvareesakul, Y., Sakakura, Y. & Hagiwara, A. (2007) Effect of tank proportions on survival of seven band grouper *Epinephelus septemfasciatus* (Thunberg) and devil stinger *Inimicus japonicus* (Cuvier) larvae. *Aquaculture Research*. 38(2), 193-200.